

How to Choose an Alcohol Sensor, A Comprehensive Guide

Original link: <https://sensor1stop.com/knowledge/how-to-choose-an-alcohol-sensor/>



How to Choose an Alcohol Sensor: A Comprehensive Guide



Choosing the right alcohol sensor for your specific needs can be a complex process, given the variety of available technologies, their applications, and the nuances of their performance characteristics. This guide will help you navigate the options and make an informed decision by exploring the types of alcohol sensors, their principles, applications, and a comparative analysis in a tabular format.

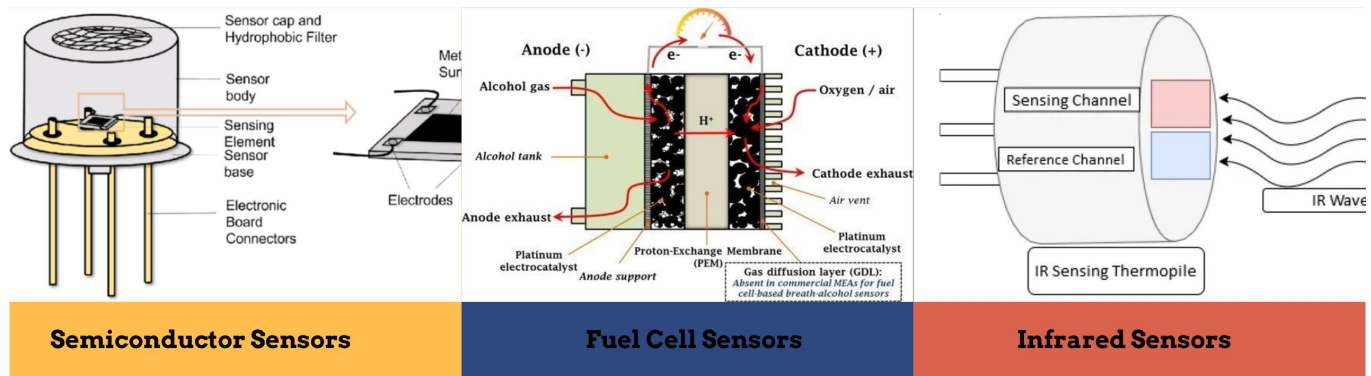

Choosing the right alcohol sensor for your specific needs can be a complex process, given the variety of available technologies, their applications, and the nuances of their performance characteristics. This guide will help you navigate the options and make an informed decision by exploring the types of alcohol sensors, their principles, applications, and a comparative analysis in a tabular format.

More About Alcohol Sensors: [What is an Alcohol Sensor: Understanding the Technology, Applications, and Implications](#)

Types of Alcohol Sensors

The main types of alcohol sensors include:

1. **Semiconductor Sensors**
2. **Fuel Cell Sensors**
3. **Infrared Sensors**

4. Optical Sensors

Semiconductor Alcohol Sensors

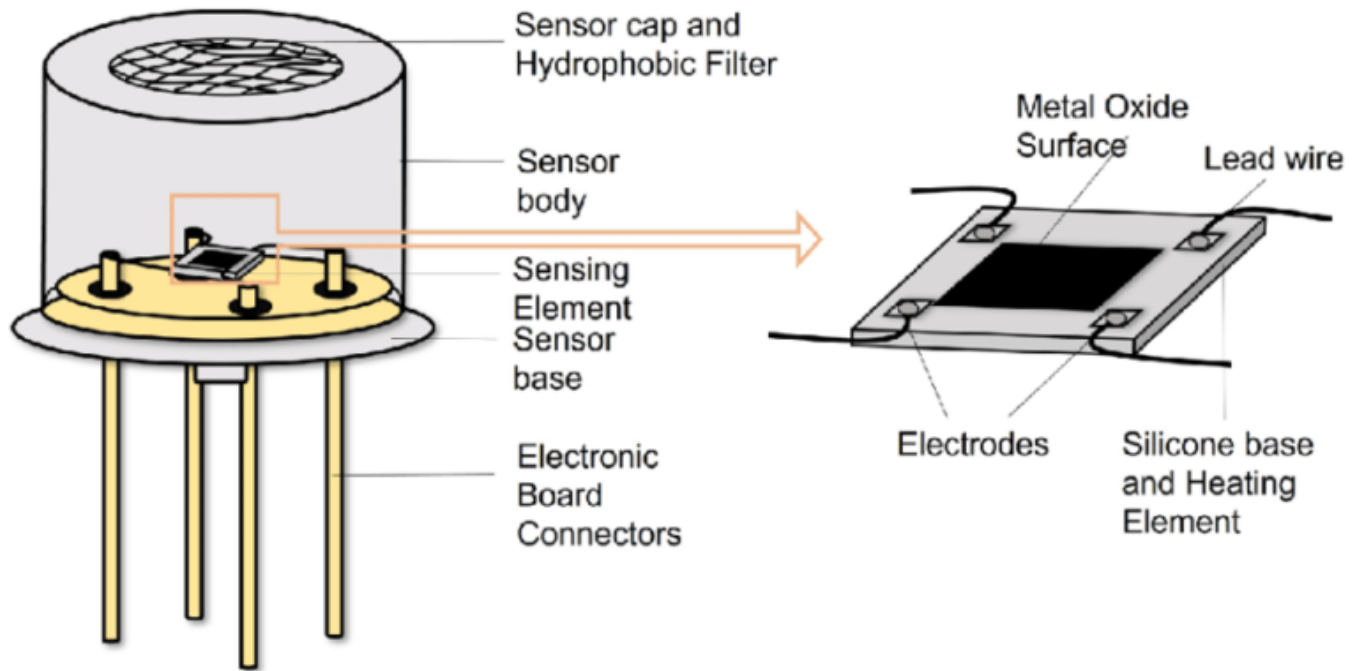

Principle: Semiconductor sensors detect alcohol by measuring changes in the electrical resistance of a semiconductor material when exposed to alcohol vapor.

Advantages:

- Cost-effective
- Compact
- Easy to manufacture

Limitations:

- Less accurate than other types
- Susceptible to interference from other gases

Applications:

- Personal breathalyzers
- Basic workplace screening

Fuel Cell Alcohol Sensors

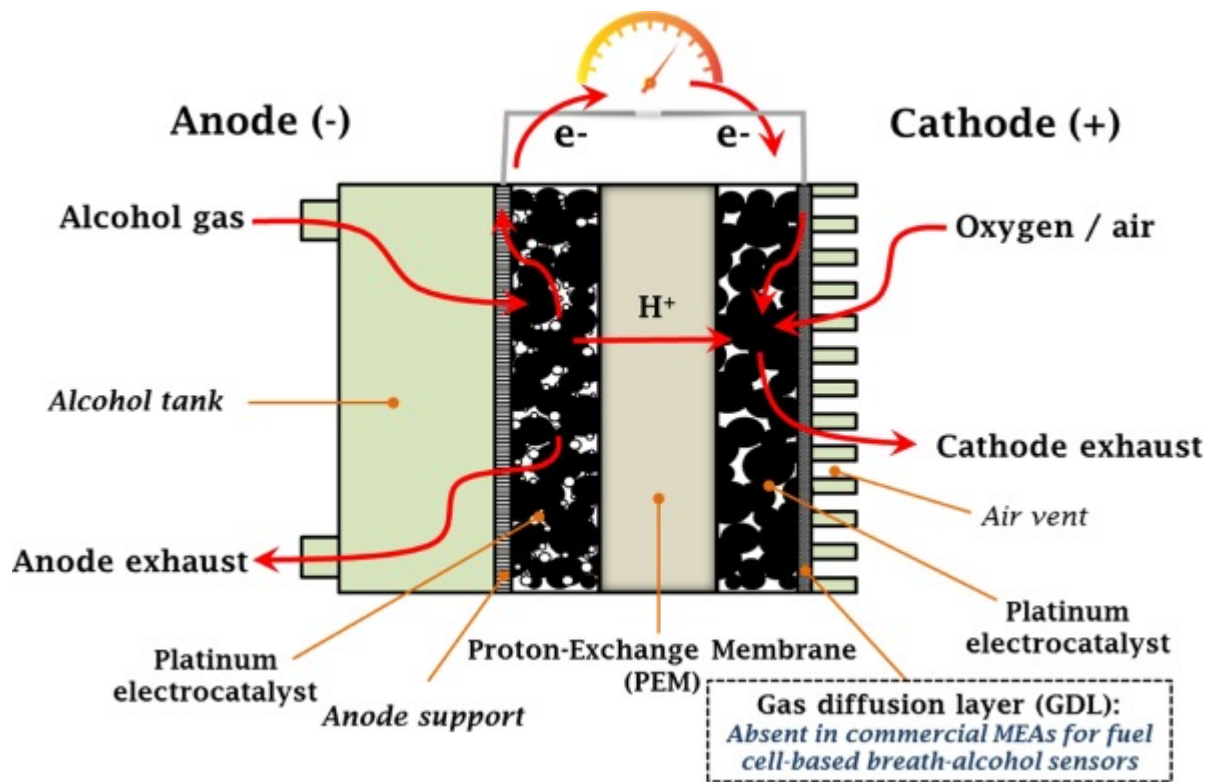

Principle: These sensors generate an electrical current through the oxidation of alcohol on a platinum-coated membrane, with the current proportional to the alcohol concentration.

Advantages:

- High accuracy
- Specific to alcohol
- Stable over time

Limitations:

- More expensive
- Requires periodic calibration

Applications:

- Law enforcement breathalyzers
- Professional workplace testing
- Personal high-accuracy breathalyzers

Infrared Alcohol Sensors

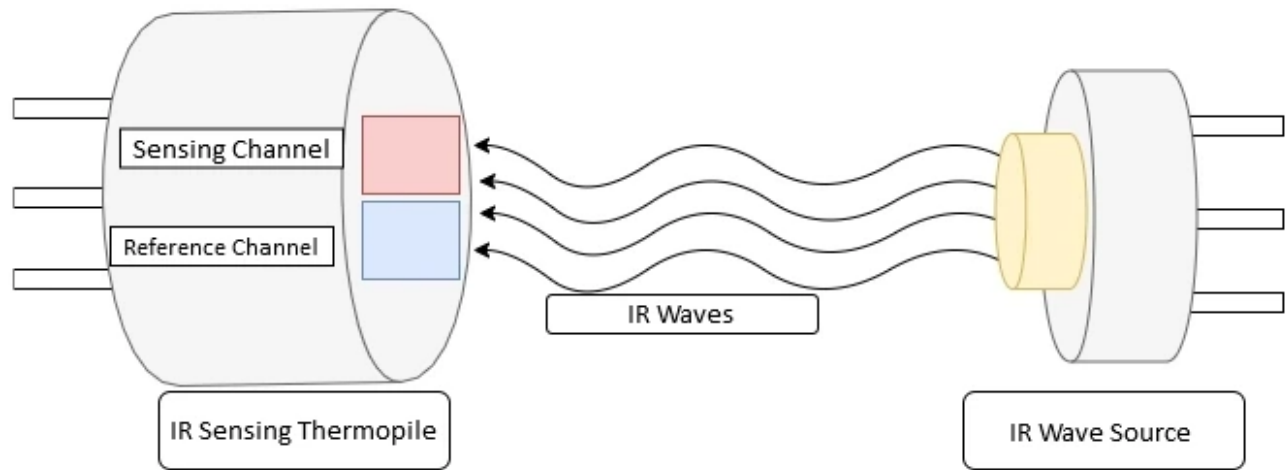

Principle: Infrared sensors measure the absorption of specific wavelengths of infrared light by alcohol molecules.

Advantages:

- Non-invasive
- Fast response time
- High accuracy

Limitations:

- Expensive
- Potential interference from other substances

Applications:

- Industrial process monitoring
- Environmental monitoring
- High-precision breathalyzers

Optical Alcohol Sensors

Principle: These sensors utilize optical techniques, such as fluorescence or Raman spectroscopy, to detect changes in optical properties when exposed to alcohol.

Advantages:

- High sensitivity and specificity
- Non-invasive applications

Limitations:

- Expensive
- Requires sophisticated instrumentation

Applications:

- Medical diagnostics
- Research and development
- High-precision industrial applications

Comparative Analysis of Alcohol Sensors

To help you choose the right alcohol sensor, the following table compares the key features, advantages, limitations, and typical applications of each sensor type.

Sensor Type	Principle	Advantages	Limitations	Applications
Semiconductor	Changes in electrical resistance of semiconductor material	Cost-effective, compact, easy to manufacture	Less accurate, susceptible to interference	Personal breathalyzers, basic workplace screening
Fuel Cell	Oxidation of alcohol on platinum-coated membrane	High accuracy, specific to alcohol, stable over time	More expensive, requires periodic calibration	Law enforcement breathalyzers, professional workplace testing, personal high-accuracy breathalyzers
Infrared	Absorption of specific wavelengths of infrared light	Non-invasive, fast response time, high accuracy	Expensive, potential interference from other substances	Industrial process monitoring, environmental monitoring, high-precision breathalyzers
Optical	Optical techniques (fluorescence, Raman spectroscopy)	High sensitivity and specificity, non-invasive	Expensive, requires sophisticated instrumentation	Medical diagnostics, research and development, high-precision industrial applications

Factors to Consider When Choosing an Alcohol Sensor

Accuracy and Precision

Accuracy and precision are critical factors, especially in applications where legal or medical decisions are made based on the results. Fuel cell and infrared sensors generally offer higher accuracy compared to semiconductor sensors.

Specificity

Specificity refers to the sensor's ability to detect alcohol without interference from other substances. Fuel cell sensors are known for their high specificity to alcohol.

Cost

Budget constraints often play a significant role in the decision-making process. Semiconductor sensors are generally more affordable, while fuel cell and infrared sensors come with higher costs but also higher accuracy and reliability.

Application Requirements

Consider the specific application needs:

- **Law Enforcement:** High accuracy and reliability are crucial; fuel cell sensors are often preferred.
- **Workplace Safety:** Depending on the required accuracy, either semiconductor or fuel cell sensors may be appropriate.
- **Medical Diagnostics:** High sensitivity and specificity are essential; optical and infrared sensors may be the best choices.
- **Personal Use:** Cost-effective solutions like semiconductor sensors or compact fuel cell breathalyzers are ideal.

Environmental Conditions

Environmental conditions such as temperature, humidity, and potential exposure to interfering substances can affect sensor performance. Ensure the chosen sensor is suitable for the operating environment.

Maintenance and Calibration

Regular maintenance and calibration are necessary to ensure the long-term accuracy and reliability of the sensor. Fuel cell sensors require periodic calibration, while semiconductor sensors may need less frequent calibration but can be less accurate.

Future Trends in Alcohol Sensor Technology

Wearable Alcohol Sensors

Wearable alcohol sensors integrated into devices like smartwatches or fitness trackers offer continuous, real-time monitoring of alcohol levels through sweat or transdermal measurements. This innovation provides a convenient and non-invasive way to track alcohol consumption.

IoT Integration

The integration of alcohol sensors with the Internet of Things (IoT) allows for real-time data transmission to centralized systems, enhancing workplace safety, medical diagnostics, and personal health management through timely data and alerts.

Advanced Materials and Sensor Technologies

Advancements in materials science and sensor technology are leading to the development of more sensitive, specific, and durable alcohol sensors. These improvements aim to reduce interference, enhance accuracy, and extend the lifespan of sensors.

Mobile Applications and Data Analytics

Mobile applications that integrate with alcohol sensors offer detailed reports, trends, and recommendations based on alcohol consumption patterns. These apps can also provide educational resources and support for individuals seeking to reduce their alcohol intake.

Improved Accessibility and Affordability

Research and development efforts are focused on making high-accuracy alcohol sensors more affordable and accessible to a broader population. This includes reducing manufacturing costs, simplifying calibration processes, and developing user-friendly interfaces.

Conclusion

Choosing the right alcohol sensor depends on various factors, including the required accuracy, specificity, cost, application needs, environmental conditions, and maintenance requirements. Understanding the principles, advantages, and limitations of different types of alcohol sensors helps in making an informed decision. As technology continues to advance, the availability of more sensitive, specific, and user-friendly alcohol sensors will expand, providing better solutions for monitoring and managing alcohol consumption in various settings. By leveraging these advancements, we can enhance public safety, support health management, and improve overall outcomes in law enforcement, workplace safety, medical diagnostics, and personal health monitoring.

Reatlled Read: [What is Alcohol: Understanding the Science, Uses, and Impacts of Alcohol](#)